



# Bomb blanket with ring

Europe-Patent No.: EP 0795260A1

NSN : 1385-12-362-3439

Art.- No.: 170194

## Technical Documentation

The set consists of the bomb blanket Art.-No: 170196 and the ballistic ring Art.-No: 170195.

The bomb blanket is manufactured from multiple layers of TWARON®. In the centre the layers are doubled. A 600 mm x 600 mm TWARON®/rubber laminate sheet gives added protection against penetration caused by the blast. A label clearly indicates the way that the blanket should be placed.

This ballistic ring is manufactured from multiple layers of wrapped TWARON®-fabric. The outer layer is made from rubberised fabric of the same material. The fabric is wound both horizontally and vertically before being bonded by a special adhesive which gives a high tensile strength to the whole structure.

**The reinforced ring is put over the suspicious object and covered by the blanket. The I.E.D. specialists are still able to x-ray the covered object and decide about further actions. (We recommend the use of INSPECTOR video systems, more details on request).**

Two fabric straps on each side of the blanket are used to remove it from the suspect object, using a hook and line system or a remote controlled manipulating vehicle (details on request).

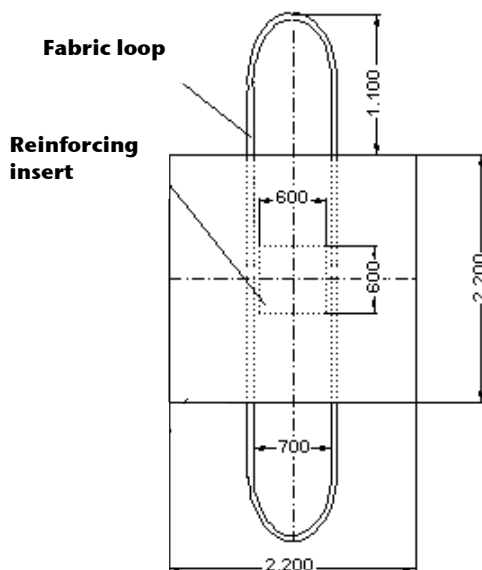

Bomb blanket Art.-No. 170196

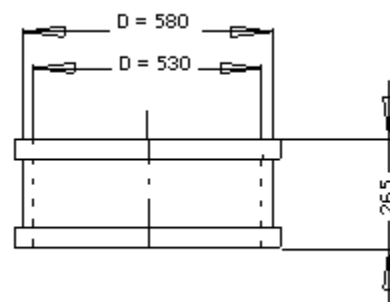

Ballistic ring, Art.-No. 170195

(Made in Germany)



Specification subject to change without notice.

O:\kataloge\english 2011\05 Anti-fragment devices\170194-6.docx

**ELP GmbH**  
**European Logistic Partners**

**Nützenberger Str. 359**  
**D 42115 Wuppertal**  
**GERMANY**

**e-mail: [elp@elp-gmbh.de](mailto:elp@elp-gmbh.de) / <http://www.elp-gmbh.de>**

**Tel.: 0049 (0)202 69894 0**  
**FAX : 0049 (0)202 69894 10**

